

Overview:

The VRM-CCG-XXX is a versatile 4HP/3U (single size Eurocard) CompactPCI® CPU board, equipped with an Intel® Core™ 2 Duo processor at 2.2GHz clock, and up to 4GB dual channel capable DDR2 RAM. Three Serial ATA channels are available for rear I/O. The VRM-CCG has been designed especially for systems which require very high performance at moderate power consumption. The VRM-CCG is provided with a high performance mobile chipset (Intel® GM965) which operates up to 800MHz FSB and up to 667MHz DDR2 memory clock for optimum system throughput. An on-board CF connector can accommodate either a CompactFlash memory card or a Microdrive®. As an alternate, a 1.8" hard disk module is available as on-board mass-storage device (option). The chipset is based on PCI Express technology and has a powerful dual-screen integrated graphics accelerator. Two Gigabit Ethernet controllers are provided for high speed connectivity. As an option, a mezzanine card is available that allows using the VRM-CCG in addition as CompactPCI® Express system slot controller (especially suited for hybrid dual backplane systems). Local expansion interface connectors can be optionally used to directly attach a mezzanine companion sideboard, either for audio- or legacy support, or equipped with PCI Express based I/O circuitry. Mezzanine cards can carry in addition a 2.5" hard disk drive. Also as an option, a suitable rear I/O transition module is available to the VRM-CCG, which provides the Serial ATA connectors.

Benefits:

- CompactPCI System Slot Controller with or without Rear I/O
- CompactPCI Express System Board Option (mezzanine expansion card)
- Hybrid Systems Option (Dual backplane CompactPCI & CompactPCI Express)
- Intel® Core™ 2 Duo Mobile Processor 2.2GHz (FSB 800MHz)
- PCI Express Mobile Chipset Intel® GM965
- 2 x 2GB DDR2 Memory (Dual channel mode capable)
- Dual-Screen graphics controller
- Dual Gigabit Ethernet Controllers
- Triple SATA 3Gbps, Intel® Matrix Raid Storage Technology
- Seven USB 2.0 channels
- On-Board CompactFlash or on-Board 1.8" Hard disk
- Mezzanine Expansion Boards available with or without PCIe
- TPM 1.2 Option (on Mezzanine Expansion Board)
- Rear I/O transition module option
- Intel® AMT 2.0 Platform Management
- RoHS compliant

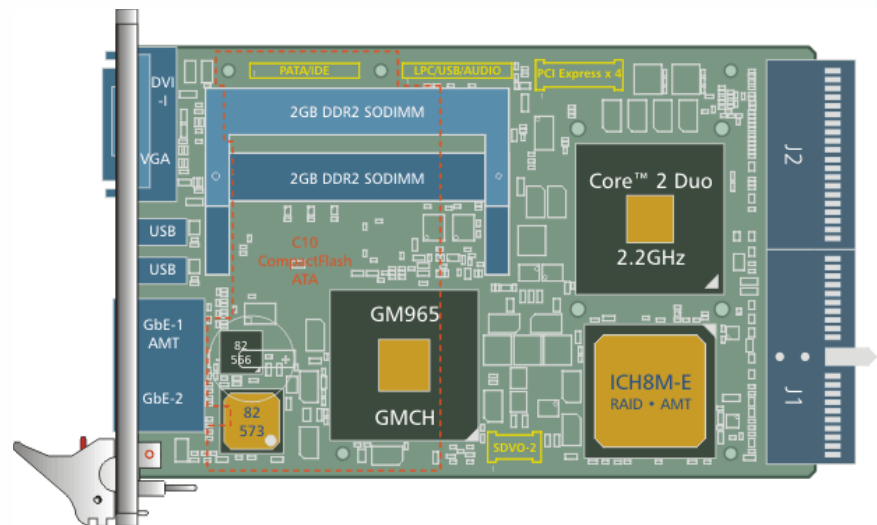



Features:

- Form Factor: Single Size CompactPCI style Eurocard (160x100mm²), front panel width 4HP (20.3mm)
- Processor: Designed for Intel® Core™ 2 Duo second generation dual core mobile processors (codename Merom), dynamic FSB switching, 800/667/533MHz FSB, maximum junction temperature 100°C, Intel® Core Multiprocessing (CMP), Intel® Virtualization Technology (VT), Intel® 64 Architecture
 - * VRM-CCG-1: 1.06GHz U7500 Intel® Core™ 2 Duo ULV, 533MHz FSB, 2MB L2 cache, TDP—10W (low power consumption)
 - * VRM-CCG-2: 1.2GHz U7600 Intel® Core™ 2 Duo ULV, 533MHz FSB, 2MB L2 cache, TDP—10W (low power consumption)
 - * VRM-CCG-4: 1.6GHz L7500 Intel® Core™ 2 Duo LV, 800MHz FSB, 4MB L2cache, TDP 17W (general purpose applications)
 - * VRM-CCG-6: 2.0GHz Intel® Celeron® M 550, 533MHz FSB, 1MB L2 cache, TDP 27W (value applications, single core)
 - * VRM-CCG-8: 2.2GHz T7500 Intel® Core™ 2 Duo, 800MHz FSB, 4MB L2 cache, TDP 35W (performance applications)
- Chipset: Intel® GM965 (Codename Crestline) chipset comprised of:
 - * GM965 Graphics/Memory Controller Hub (GMCH) with Intel® Graphics Media Accelerator (GMA), dual independent display, DirectX 10 and Open GL 2.0 support, generation 4 graphics core, 1.5 x 945GM graphics performance, AMT manageability engine.
 - * ICH8M-E Ethernet I/O Controller Hub, integrated GbE MAC, dual USB EHCI controllers (no shared bandwidth), 3 x SATA 3Gbps, MST & RAID, AMT, unified SPI Flash support.
- Memory: Dual 200-pin SO-DIMM socket, DDR2 667 SDRAM (PC5300), 4GB (2 x 2GB) maximum, single or dual channel mode operation, configurations:
 - * 256Mb, 512Mb, 1Gb, 2Gb technologies for x 8 and x16 devices
 - * Dual channel symmetric— memory addresses interleaved for increased performance, but memory module sizes must match
 - * Intel® Flex Memory Technology (dual channel interleaved mode with unequal memory population)- memory module sizes may be unequal in both the channels
 - * Dual channel asymmetric— memory module sizes may differ, no memory in the second channel (single-channel)
 - * Channel 0 must be populated first
- Video I/O: Analog monitor and digital flat-panel display support by DVI-I connector (front panel), up to QXGA 2048x1536 pixel 16M colours @ 75Hz (refresh rate (analog) , up to 1600 x 1200 pixel 16M colours @ 60Hz (digital), incorporates PanelLink Digital technology (Silicon Image)
 - * Dual screen capable 2 x 1600 x 1200 pixel (one display attached to the front panel, the other to the back panel, or both to the front panel by means of a DVI-I to DVI-D/VGA splitter cable, or secondary DVI-D connector on mezzanine sideboard)
 - * Front panel option: D-Sub (female HD15) VGA connector available, replaces DVI-I connector
 - * Rear I/O option: Analog video across J2/P2 (CCT-RIO rear I/O transition module)
 - * Mezzanine option: Secondary DVI-D connector at mezzanine card front panel allows for dual digital flat panel operation, suitable mezzanine modules (VRM-CCH) and VRM-CCJ.
- USB I/O: All ports over-current protected, data transfer rate of up to 480Mbps, conforming to USB2.0
 - * 2 x USB type A connector (front panel)
 - * 3 x USB J2/P2 Rear I/O option (VRM-CCT-RIO rear I/O transition module)
 - * 2x USB ports expansion interface option (VRM-CCH or VRM-CCJ mezzanine companion board)
 - * USB Flash drive module C15-DON option (USB stick on-board)
 - * Dual EHCI / five UCHI controllers provided by ICH8
- Ethernet I/O: Two 10/100/1000Mbps Gigabit Ethernet controller, accessible via RJ45 jacks from the front panel
 - * ETH1 equipped with Intel® 82566 PHY (codename Nineveh), serves also as AMT out of band communication path (MAC provided by ICH8)
 - * ETH2 equipped with Intel® 82573 GbE controller connected to PCIe lane
 - * Option ETH2 Gigabit Ethernet configurable (BIOS) across J2/P2 with attached VRM-CCT RIO rear I/O transition module
- Mezzanine-Sideboard I/O: LPC/USB/Audio (Super I/O, USB and Azalia HD Audio) expansion interface connector
 - * ATA/IDE expansion connector / PCI Express 4-lane (configurable as 1 link x 4) high speed expansion interface connector
 - * SDVO secondary digital graphics port high speed expansion connector
 - * Suitable mezzanine companion boards available:
 - * VRM-CCE— Front panel options COM, USB, IEEE 1394 (FireWire), on board hard disk drive 1.8" or 2.5"
 - * VRM-CCH— Front panel options DVI-D, COM, USB, audio in (analog), audio out (analog), digital audio, on board hard disk drive 1.8" or 2.5" option TPM 1.2
 - * VRM-CCJ— Front panel options DVI-D, COM, USB, IEEE 1394 (FireWire), on board hard disk drive 1.8" or 2.5", CompactPCI Express system slot controller, option TPM 1.2
 - * C10-1-CFA CompactFlash adapter module
 - * C10-2-CFA 1.8" hard disk module
 - * C15-DON on board USB stick module (USB flash disk)



VRM- CCG-XXX

Product Datasheet

Features cont.:

- PATA ((DE) - Ultra ATA/100 connector, handover to VRM-CCE/VRM-CCH/VRM-CCJ mezzanine companion board with optional on-board 2.5" hard disk drive or external device
 - * CompactFlash socket C10-1-CFA supplied for a CFA ATA memory card or Microdrive®
 - * Option 1.8" on-board hard disk module C10-2-CFA, replaces CompactFlash facility
 - * SATA (Serial ATA)- Triple-channel Serial ATA 3Gbps available for J2/P2 rear I/O option
 - * Suitable rear I/O transition module VRM-CCT-RIO (2 x system-internal SATA, 1 x eSATA for attachment of external devices)
 - * Intel® Matrix Storage Technology for MST (Raid 1, 0, Matrix Raid)
- CompactPCI®- ICH8 integrated 32-bit PCI bridge, 133Mbps CPCI master, additional PCI arbiter in PLD for fully figured 8-slot CompactPCI Backplane
- PCI Express/ CompactPCI® Express-
 - * VRM-CCG can act also as CompactPCI Express System Board (system slot controller) by optionally available mezzanine expansion card (sideboard) VRM-CCJ
 - * PCIe 4-link configuration (4-lanes each), for up to 4 CPCI peripheral slots type 1 and/or type 2 on a passive PCIe backplane
 - * Suitable also for hybrid CPCI/PCIe systems/backplane (i.e. Schroff)
- J2/P2 Rear I/O– 3 x Serial ATA (SATA), 2 x system internal SATA connectors, 1 x external eSATA connector
 - * GB Ethernet (switched by BIOS between front panel I/O and rear I/O)
 - * 3 x USB
 - * VGA Analog Video (option)
 - * Keyboard/mouse
 - * COM port (TTL level)
 - * Suitable rear I/O transition module VRM-CCT-RIO available
- Platform Management– AMT 2.0 Intel® Active Management Technology
 - * Manageability Engine (ME) microcontroller in the GMCH
 - * Independent manageability firmware, stored in SPI Flash
 - * Secure Computing– Option Trusted Platform Module TPM 1.2 according to Trusted Computing Group specifications, available on mezzanine boards VRM-CCH/VRM-CCJ
 - * Crypto engine silicon brands Infineon or Atmel at users choice
- BIOS– Phoenix BIOS with EKF enhancements
 - * Updates available from website (upon request)
- Drivers– Intel® graphics drivers
 - * Intel® networking drivers
 - * Intel® Matrix Storage Manager software
- Typical Power Requirements-

Board	+3.3V +0.17V/-0.1V		+5V +0.25V/-0.15V	
	Max Power LFM/HFM ¹	WinXP idle LFM/HFM ¹	Max Power LFM/HFM ¹	WinXP Idle LFM/HFM ¹
VRM-CCG-1	tbd	tbd	tbd	tbd
VRM-CCG-2	tbd	tbd	tbd	tbd
VRM-CCG-4	tbd	tbd	tbd	tbd
VRM-CCG-8	tbd	tbd	tbd	tbd

- Thermal Conditions/Environmental Conditions-
 - * Operating Temperature: 0°C ... -60°C
 - * Storage Temperature: -40°C ... +85°C , max. gradient 5°C/min
 - * Humidity– 5% ... 95% non condensing
 - * Altitude- ~300m ... _3000m
 - * Shock– 15g 0.33ms, 6g 6ms
 - * Vibration– 1g 5-2000Hz
- EC Regulations– EN55022, EN55024, EN60950-1 (UL60950-1/IEC60950-1). 2002/95/EDC (RoHS)
- MTBF: tbd
- Typical Performance Rating Measured with PCMark2005 under WinXP, 2 x 1GB DDR2 667- tbd

¹ Intel SpeedStep® Frequency Modes. LFM: Low Frequency Mode, HFM: High Frequency Mode



V Rose
Microsystems, Inc.

VRM- CCG-XXX

Product Datasheet

Block Diagram:

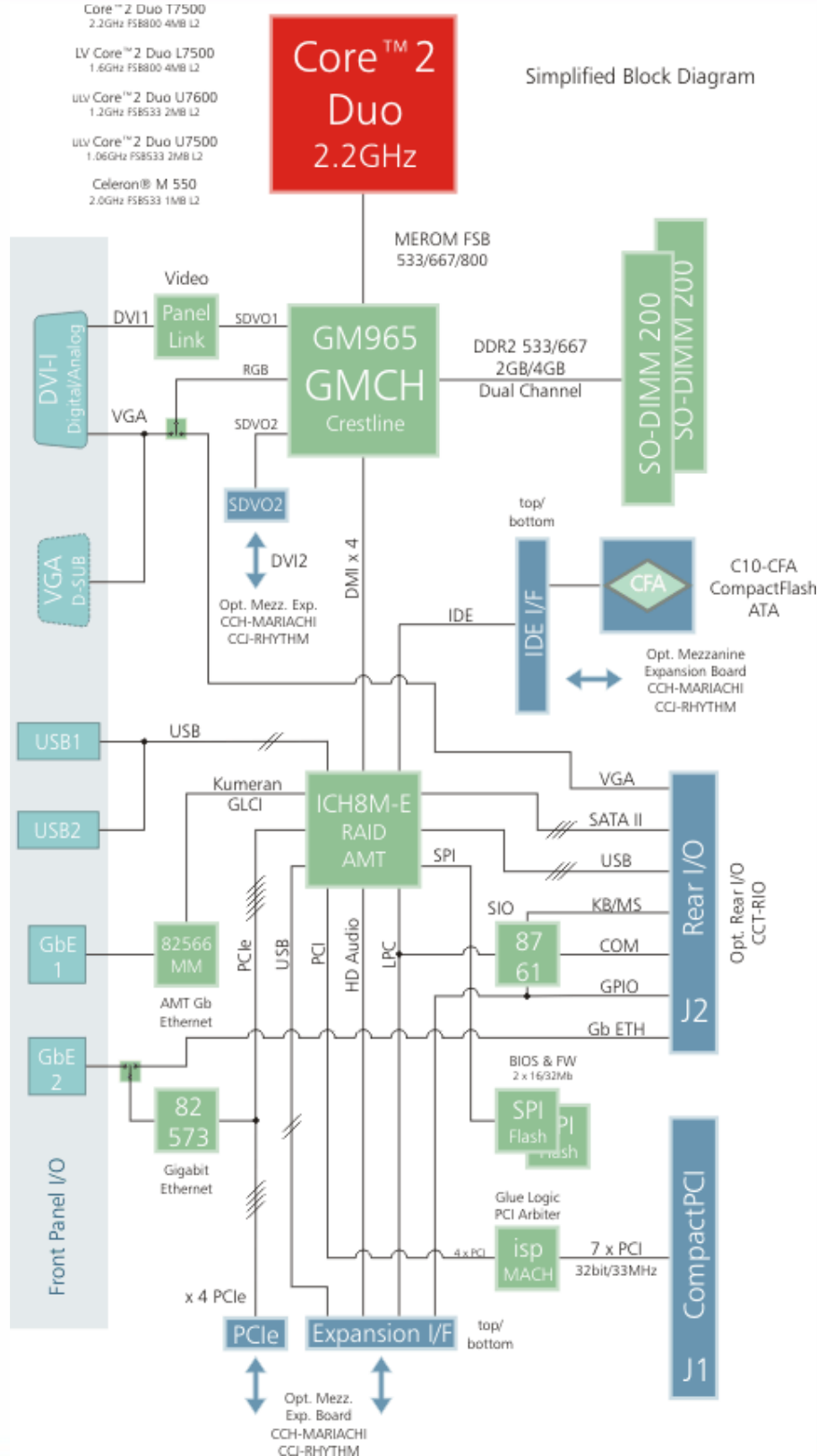



Available as a rear I/O expansion board to the VRM-CCG CPU card, the VRM-CCT-RIO is provided with several I/O port connectors, to be used either in addition to the VRM-CCG front panel connectors or alternatively. Being mainly a passive rear I/O transition module, groups of signals from the VRM-CCG CPU board are passed across the CompactPCI J2/P2 connector to the VRM-CCT-RIO. Some of the data lines are available locally on the VRM-CCT board for system internal wiring only, while other connectors such as VGA-Video and Gigabit Ethernet are mounted in the back panel for external use. USB and SATA (eSATA) channels are provided both on-board and externally. Typically the VRM-CCT-RIO is equipped with a 4-HP rear panel (20.3mm width). As a custom specific option, an 8-HP panel is available with additional connectors. Utilization of the VRM-CCT-RIO transition module adds a level of I/O functionality that is not available with the VRM-CCG CPU board alone. Further on, swapping the CPU card is simplified by means of rear I/O, which is important for efficient system maintenance (MTTR). Be sure to have ordered a VRM-CCG rear I/O capable version and also the CPCI backplane suitable for rear I/O in order to use the VRM-CCT-RIO transition module.

Ordering Information

- **VRM-CCG-1RD:** 3U/4HP, Core™ 2 Duo U7500 1.06GHz FSB 533MHz 2MB L2 cache, dual socket DDR2 SO-DIMM up to 4GB, DVI-I dual screen, dual GB-ETH, 7 x USB, 1 x PATA, 3 x SATA-2, 4 x PCIe, CF Card slot, suitable for rear I/O across J2. *(targeted for low power applications)*
- **VRM-CCG-2RD:** Similar to CCG-1 Core™ 2 Duo U7600 1.2GHz FSB 533MHz 2MB L2 cache *(targeted for low power applications)*
- **VRM-CCG-4RD:** Similar to VRM-CCG-1, Core™ 2 Duo L7500 1.6GHz FSB 800MHz 4MB L2 cache *(targeted for general purpose applications)*
- **VRM-CCG-6RD:** Similar to VRM-CCG-1, Celeron® M 550 2.0GHz (single core processor) FSB 533MHz 1MB L2 cache *(targeted for value systems)*
- **VRM-CCG-8RD:** Similar to VRM-CCG-1, Core™ 2 Duo T7500 2.2GHz FSB 800MHz 4MB L2 cache *(targeted for high performance applications)*
- **VRM-CCE-1:** 3U/4HP Mezzanine expansion board complementing the VRM-CCG, front panel width 4HP, 2 x RS232, 2 x USB, 2 x 1394a FireWire 400Mbps, mounting on top of the VRM-CCG, option on-board hard disk
- **VRM-CCH-1:** 3U/4HP Mezzanine expansion board for VRM-CCG, HD audio codec (Azalia), option TPM 1.2, DVI-D digital video, analog audio, RS-232 (COM), w/o USB, option on-board hard disk.
- **VRM-CCH-2:** Similar to VRM-CCH-1, 2 x COM, USB, analog audio, w/o DVI-D
- **VRM-CCH-3:** Similar to VRM-CCH-1, DVI-D, analog audio, digital audio, w/o USB & COM
- **VRM-CCH-4:** Similar to VRM-CCH-1, COM, USB, analog audio, digital audio, w/o DVI-D
- **VRM-CCJ-1:** 3U/4HP Mezzanine expansion board for VRM-CCG, System slot sideboard for CompactPCI Express backplanes, 24-port PCI Express packet switch, DVI-D, 1 x USB, 2 x FireWire, 1 x RS-232 (COM), on board hard disk option, option TPM 1.2
- **VRM-CCJ-2:** Similar to VRM-CCJ-1, 2 x COM, USB, 2 x FireWire, w/o DVI-D
- **VRM-CCT-1-RIO:** Rear I/O transition module for VRM-CCG with SATA connectors