

Overview:

The **VRM-CG2** CompactPCI 3U GPS Receiver Module is provided with a high performance receiver engine continuously tracking all satellites in view for a time accuracy better than 1us and horizontal accuracy better than 3m. The receiver is compatible with passive or active antennas and supports the NMEA-0183 data protocol, thus allowing nearly any GPS application program to be used with it. The **VRM-CG2** module lends full GPS functionality to any CompactPCI® system. The **VRM-CG2** incorporates a highly integrated digital GPS receiver, which uses the SiRF-starII chipset and is accommodated on a miniature daughter board as an exchangeable mezzanine sub-assembly. The 12-channel architecture provides rapid Time-To-First-Fix (TTFF) under all start-up conditions. The receiver decodes and processes signals from all visible GPS satellites, thereby producing a highly accurate and robust navigation solution. In a typical situation, a horizontal accuracy better than 3m can be achieved. The external GPS antenna connects to the front panel mounted SMB style jack and must have reasonable visibility of the sky. For best performance, use an active antenna (+5V or +3.3V selectable power), in particular for a cable length of 3m and beyond.

Under certain conditions, differential RTCM SC-104 data capability can further enhance the positioning accuracy. For that, the **VRM-CG2** is equipped with an additional serial port for communication with an external DGPS (Differential GPS) receiver.

With respect to the CompactPCI bus, the **VRM-CG2** appears as a quad serial adapter card, based on 16C550 compatible PCI UARTs (which are also known as COM-ports in a typical PC). The first serial port of the **VRM-CG2** is for on-board use only. It serves as the communications interface to the GPS receiver. Commands and data can be sent to and received from the GPS daughter board according to the NMEA-0183 standard protocol. When operated in NMEA ASCII mode, the moderate transmission rate of 4800bps cares for low interrupt load of the system host. As an option, the SiRF binary raw data protocol allows much higher throughput. The second serial port is intended either as external DGPS interface (read only), or as a general purpose RS-232E communications channel. The wiring of the front panel mounted 9-pin male D-SUB connector is identical to desktop PC COM ports. When receiving differential DGPS data at 9600bps according to the RTCM SC-104 standard, the GPS daughter module uses this information for its internal calculations to sharpen the positioning data. The second serial interface is also directly readable by the system host. Programs as LabMon can process DGPS data in parallel to the GPS receiver data for presentation. The remaining two serial ports are currently not in use. However, the **VRM-CG2** can be optionally equipped with connectors suitable for attachment of external PHY transceiver modules.

The **VRM-CG2** provides a pulse output (1pps) with better than 1us timing accuracy, which can be used to generate interrupts in order to synchronize processes. Available by download, our utility WinGPS displays the GPS data and allows synchronizing the system clock with the UTC (Universal Time Coordinated). In addition, the internet is full of GPS shareware tools. The common basis of most applications is the NMEA-0183 protocol, so that they should be usable with the **VRM-CG2** without any modification. Furthermore, there are various commercial GPS application programs available, mostly allowing comfortable cartographical visualization.



Features:

- Board Form Factor: 3U Eurocard (100 x 160mm²), front panel width 20.3mm (4HP)
- Serial interfaces: Device: 16C550 compatible Quad PCI UART Oxford OXmPCI954 asynchronous serial protocol:
 - 1 startbit; 7 or 8 databits; 1 or 2 stopbits; optional odd/even parity; bitrates up to 15Mbps
 - SP1 (internally): SP1/SP2: typical settings for GPS operation SP1=4800Baud (GPS NMEA-0183), SP2=9600Baud (DGPS RTCM SC-104)
 - SP2 (externally and internally): SP2 front panel connector: PC compatible D-SUB connector 9-pin male, to be used either as DGPS input or as universal serial COM port, ESD protection 15kV, RS-232E transceiver can be disabled by removing jumper J-SP2 (option)
 - SP3/SP4: on-board pin headers suitable for attachment of CU7-RS485 and CU8-RS232 PHY-modules (option)
- Serial driver software (COM port emulation) available
- GPS Receiver: Exchangeable modular 12-channel receiver, chipset SiRF-starII, SMB jack for 1575, 42MHz (L1 Band) GPS antenna, supply 0V (passive antenna), +5V, +3.3V (active antenna) selectable with jumper J-ANT
- Accuracy (horizontal) better than 3m (CEP), 5m (2 dRMS)
- Acquisition performance: hot start 8s, warm start 38s, cold start 45s
- Dead Reckoning capability
- SRAM and RTC data non-volatile buffered by Lithium cell 190mAh (>10000h)
- Selected NMEA-0183 ASCII messages: latitude, longitude, elevation, velocity, heading, time, satellite tracking status, command/control messages (primary serial I/F)
- SiRF binary protocol: raw data (primary serial I/F)
- RTCM ASCII protocol (secondary serial I/F)
- 1pps output with better than 1us timing accuracy
- CompactPCI® Bus: 32-bit 33MHz (133MB/s), +5V/ +3.3V_{I/O} (J1 connector not keyed)
- Power Consumption: $-5V \pm 0.25V$ 0.1A max. / $+3.3V \pm 0.15V$ 0.15A max.
- Environmental Conditions: Operating Temperature: -40°C ... +85°C, Storage Temperature: -40°C... +85°C, Humidity: 5% to 95% non-condensing, Altitude: -300m ... +18000m, Shock: 15g 0.33ms, 6g 6ms, Vibration: 1g 5-2000Hz.
- EC Regulations: EN55022, EN55024, EN60950-1 (UL60950-1/IEC60950-1), 2002/95/EC (RoHS)
- MTBF: tbd

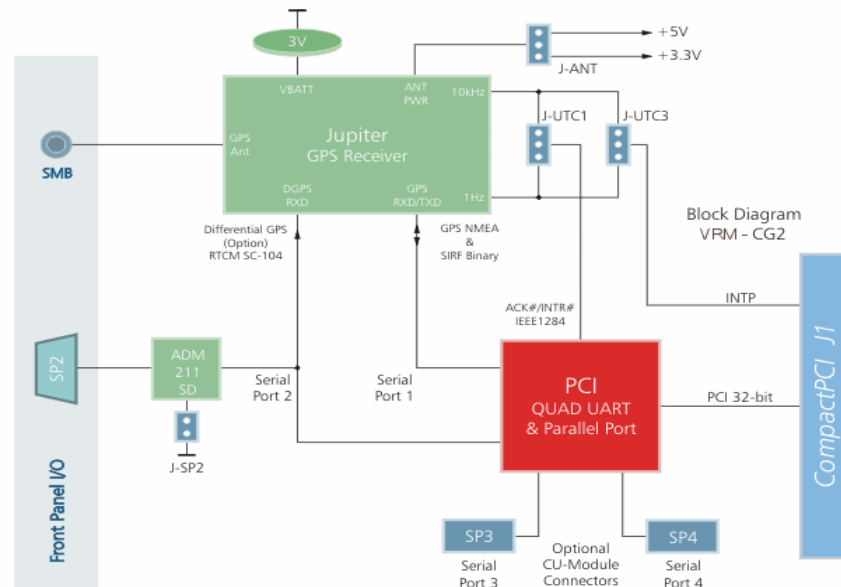

Ordering Options:

- VRM-CG2: 3U CompactPCI host adapter, 12-channel GPS receiver
- VRM-CR9-5: Front panel expansion kit 3U—6U
- VRM-940.80.210125.1: GPS antenna, active +5V, SMB connector, 5M cable length
- VRM-940.80.90100.1: External DGPS LW receiver box, including ALF license (Accurate Positioning by Low Frequency, Transmitter Mainflingen/Frankfurt, receiver radius about 650km), not required while deactivation Of GPS SA function.