

Overview:

The VRM-PANEL6172 is a 17" TFT High Brightness Industrial LCD Monitor.



Features:

- NEMA 4/12 (IP65) compliant panel mounting flat panel monitor (VRM-PANEL6172-P)
- Open frame flat panel monitor (VRM-PANEL6172-0)
- 17.1" TFT 250nit high brightness SVGA LCD
- Supporting various types of touch screen for KIOSK & P.O.I. application
- PC-VGA input ports supporting
- Easy mounting design through front panel or VESA FPMPMI mounting hole

Specifications:

Front Bezel	NEMA 4/IP65 compliant
LCD	
	Display Type: 17" TFT LCD
	Max. Resolution: 1280 x 1024
	Max. colors: 16M
	Active area (mm): 337 x 270
	Pixel pitch (mm): 0.264 x 0.264
	Backlight: 4 CCFL
	Brightness (cd/m2): 250 (TYP)
Mounting	Panel mount, rack mount, wall mount, rear mounting or VESA FPMPMI mount (Video Electronics Standards Association Flat Panel Monitor Physical Mounting Interface)
Display Control	OSD (On Screen Display)
Display Mode	VGA 640x 350(70Hz) VGA 720x 400(70Hz) VGA 640 x 480 (60/ 72/ 75Hz) SVGA 800 x 600 (60/ 72/ 75Hz) XGA 1024 x 768 (60/ 70/ 75Hz) SXGA 1080 x 1024 (60/ 70/ 75Hz)
Input Signal	VGA Video: R.G.B. analog 0.7V peak-to-peak Touch screen: Serial RS-232
I/O Connectors	D-Sub 9 pin (male) RS-232 x 1 for touch screen version D-Sub 15 x 1 (female) for VGA input DC Power input



VRM-PANEL6172

Product Datasheet

Specifications continued:

Power Adapter	External AC/ DC power adapter		
Touch screen	Thickness:	Resistive: 3mm	Capacitive: 3mm
	Touch point Density:	Resistive: 100,000 points/in ²	Capacitive: 1,024 points/axis
	Line Transmission:	Resistive: 75%	Capacitive: 85%
	Power Consumption:	Resistive: +5V @ 100mA	Capacitive: +5V @ 100mA
	Touch Life:	Resistive: 35 million touches	Capacitive: 20 million touches
	Controller Interface: RS-232 D-type 9-pin male connector		
Dimensions	VRM-PANEL6172-P:	19" W x 2.29" H x 13.96" D	
	VRM-PANEL6172-O:	16.89"W x 2.08"H x 13.3" D	
Weights	VRM-PANEL6172-P:	7Kg	
	VRM-PANEL6172-O:	5.5Kg	
Environment	Operation Temperature Range:	0C – 40C	
	Storage Temperature Range:	-20C – 60C	
	Relative Humidity:	20% - 90% RH	

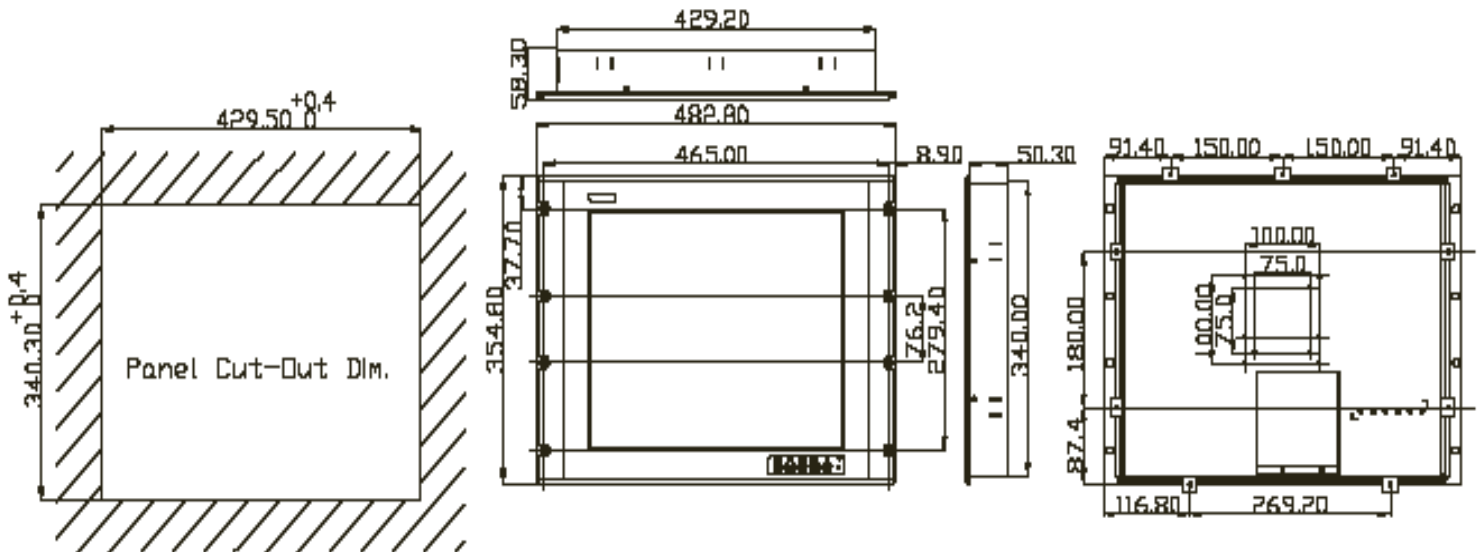

Ordering options:

- **Panel & Rack Mount Monitor:**
 - VRM-PANEL6172-PC: Touch screen 3mm Capacitive
 - VRM-PANEL6172-PR: Touch screen 3mm Resistive
 - VRM-PANEL6172-PG: Touch screen 3mm Glass
- **Open Frame Monitor:**
 - VRM-PANEL6172-OC: Touch screen 3mm Capacitive
 - VRM-PANEL6172-OR: Touch screen 3mm Resistive
 - VRM-PANEL6172-OG: Touch screen 3mm Glass